



## Passive house with ground-coupled heat pump compact unit and ventilation heat recovery



### Contribution of the Austrian national project

### Summary

The Austrian Institute of Technology developed a standardised heat pump monitoring as quality control measure.

This Best Practice Sheet presents field monitoring results of a brine-to-water heat pump compact unit with ventilation heat recovery for the operation modes space heating, DHW, space cooling and ventilation in one unit. The compact unit is installed in a passive house with a specific heat load of  $17 \text{ W/m}^2$ . While the space heating energy is emitted to the room by a low temperature floor heating system, the passive space cooling energy uses a thermally-activated ceiling. For the compact unit an extended monitoring has been performed.

The overall seasonal performance of the generator SPF-G reaches a value of 4.1. In space heating mode, a good performance factor of 4.3 is reached, while the generator SPF in DHW operation is with 3.7 high and benefits from the higher ground temperature in summertime due to the passive cooling operation.

The passive cooling operation by direct coupling of the horizontal ground source collector to the thermally activated ceiling reaches an SPF-G of 9.0, which is a good performance factor, as well, and is in the range of SPF values measured with borehole heat exchangers in residential applications.

Compared to a condensing gas boiler of high efficiency the heat pump system can reduce the  $\text{CO}_2$  emission by 59% and reaches a seasonal performance factor based on primary energy of 3.3 and thereby a reduction of primary energy of 70%, referring to efficiencies, primary energy and emission factors used in Austria.

### Building data

- Location: Judendorf-Straßengel, Styria, Austria
- Detached single family passive house, 4 inhabitants
- Year of commissioning: 2008
- lightweight construction, heated area  $210 \text{ m}^2$
- Design heat load (EN 12831):  $3.5 \text{ kW}$  ( $17 \text{ W/m}^2$ )



## Introduction

The Austrian Institute of Technology (AIT) has developed a standardised monitoring method for heat pump systems in order to enhance the quality management in heat pump installations. The monitoring method is an instrument to prove the functionality and performance of installed heat pump systems. In the course of the IEA HPP Annex 32 project, heat pump systems were tested under real conditions in order to evaluate their efficiency. Therefore, nine conventional heat pump systems and two compact units, which were situated in Upper-, Lower Austria and Styria, had been analysed. In the case of two ground-source heat pump compact units with ventilation heat recovery installed in passive houses an extended monitoring has been performed, which includes also the space heating circulation pump. Results are used to prove the functionality and performance of the system, since they have recently been introduced into the market.

## Technical concept

The building is designed according to the passive house standard which has the main requirements of max. space heating energy need of  $15 \text{ kWh}/(\text{m}^2 \cdot \text{a})$  and an approved air-tightness of the building envelope  $n_{50}$  of max.  $0.6 \text{ h}^{-1}$ .

The building is equipped with a highly integrated water heat pump compact unit with ventilation heat recovery which covers the building functions space heating (SH), domestic hot water (DHW), space cooling (SC) and ventilation with one unit. Contrary to common heat pump compact unit designs for passive houses, where the heat emission is provided by the ventilation system, i.e. the system is equipped with air heating and uses solely exhaust air as heat source, this system concept uses a ground source and a hydronic emission system, which enables higher capacities and lower supply temperatures. In this case a  $130 \text{ m}^2$  floor heating is used. The nominal heating capacity of the heat pump is  $3.3 \text{ kW}$  at B0/W35 and the design temperatures of the floor heating  $35 \text{ }^\circ\text{C}/30 \text{ }^\circ\text{C}$ . The source system consists of a  $200 \text{ m}$  horizontal ground collector, which also provides passive space cooling in summertime. For the emission of cooling power to the room, the system does not use the floor as same emission system as in space heating mode, but an additional activation of the ceiling with  $200 \text{ m}$  of pipe embedded in the concrete is used. Thereby, the passive cooling can be operated with even higher supply temperatures near the indoor temperature, since the ceiling yields a better heat transfer in cooling mode than the floor.

Moreover, a  $300 \text{ l}$  domestic hot water storage is integrated in the casing, which is charged by a desuperheater. For preheating of the outdoor air of the comfort ventilation system the heat pump includes a condensate subcooling.

## Market status

The heat pump compact unit is available on the market.

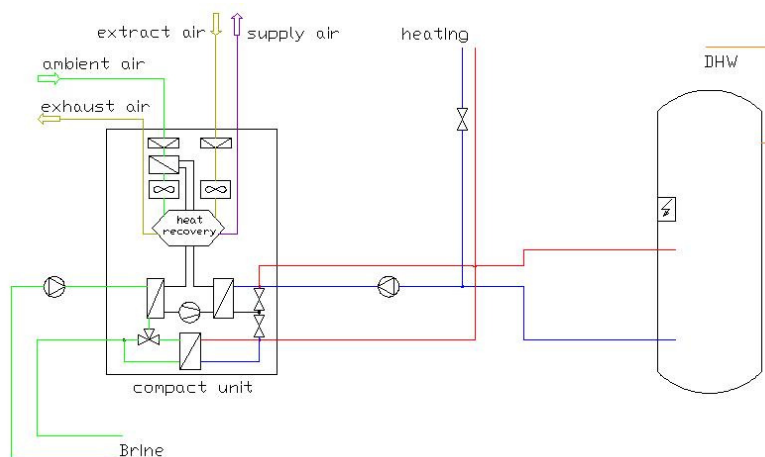

Sketch of the ground-coupled heat pump compact unit with ventilation heat recovery



The front view of the passive house



The ground-coupled compact unit with heat pump and ventilation heat recovery

### Technical data of the unit

Heat pump unit:	brine-to-water heat pump compact unit with ventilation heat recovery
Ground-source system:	200 m horizontal collector
Capacity of the source:	2.5 kW (12.5 W/m)
Thermal output/COP:	B0/W35: 3.3 kW / 4.5
Floor heating emission system:	$130 \text{ m}^2$
Ceiling emission for space cooling:	$200 \text{ m}^2$
Design temperatures	$30 \text{ }^\circ\text{C}/25 \text{ }^\circ\text{C}$
DHW system:	
Design temp.:	$52 \text{ }^\circ\text{C}$
DHW storage:	300 l
Ventilation system:	
Volume flow:	$135 \text{ m}^3/\text{h}$
Heat recovery efficiency:	85%
Nom. Fan power:	2x35 W



## Field monitoring

The evaluation was made based on three system boundaries including the generation system which comprises the heat pump and eventually installed back-up heaters as well as the source system, and on the other hand the system including sink pumps. Thus, in- and outlet temperatures as well as mass flows of the heat pump source and sink side are monitored in a 1 s interval and stored as 15 min average values. The electrical energy consumed by the heat pump compressor, the compressor on-/ off cycles and the operating hours are registered every 15 min to characterise the performance.

The monitoring period covers year-round monitoring data from Oct. 2008 to Oct. 2009.

The total energy produced by the heat pump and source system in the monitored period was 9369 kWh. 62% or 5823 kWh corresponding to 27.7 kWh/(m<sup>2</sup>a) is consumed for space heating operation which is consistent to the low energy building better than the legal requirement of the period.

The annual DHW consumption is with 1539 kWh quite low, but due to the low space heating consumption still 21% of the total consumption of space heating and DHW. 20% is a typical range of low energy houses.

919 kWh were used for pre-heating the outdoor air of the comfort ventilation system by the subcooler of the heat pump.

The total corresponding electrical energy consumed for the space heating, DHW, space cooling and ventilation is 2640 kWh.

The SPF<sub>1</sub> of the heat pump, without auxiliary drives, is 4.6 for the measured period. The SPF<sub>2</sub> of the generator system including source auxiliary energy was split up into the SPF<sub>2</sub> for heating and the SPF<sub>2</sub> for domestic hot water. The whole system reached an SPF<sub>2</sub>-value of 4.1. The space heating reached a value of 4.3 and the domestic hot water production 3.7. The high seasonal performance factor for DHW is due to the high heat source temperature during summer, which is increased by the passive cooling operation. By considering all auxiliary drives the SPF<sub>3</sub> reached a value of 3.4. The passive ground-coupled cooling mode reaches an SPF of 9.0.

The average outlet temperature of the heat pump was 29.2 °C for the measured period, and the average source temperature at the outlet of the ground collector was 2.9 °C.

The highest monthly averaged performance factors are registered in the transitional period in October and November with low supply temperatures in the space heating mode.

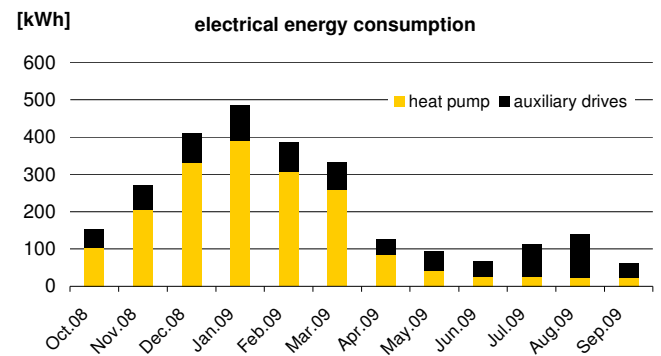
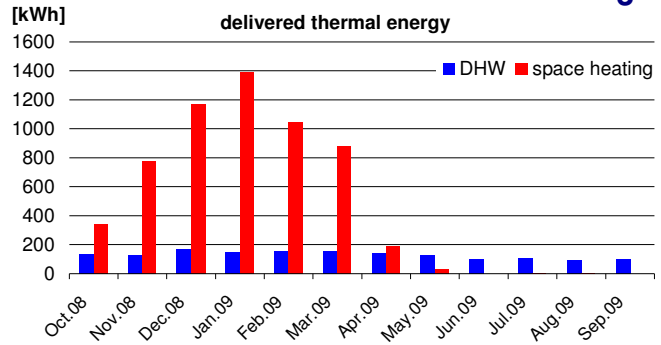

Energy delivered and consumed in 2008/2009

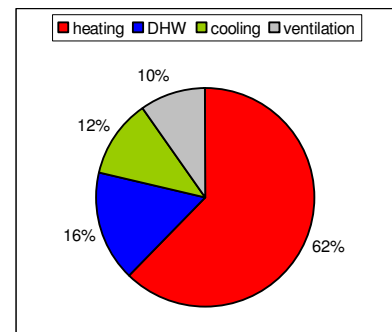

Space Heating:	5823 kWh	Ventilation:	919 kWh
Hot water:	1539 kWh	Cooling:	1088 kWh
<b>Total Output:</b>	<b>9369 kWh</b>	<b>Energy Input:</b>	<b>2640 kWh</b>

Energy delivered and consumed in 2008/2009

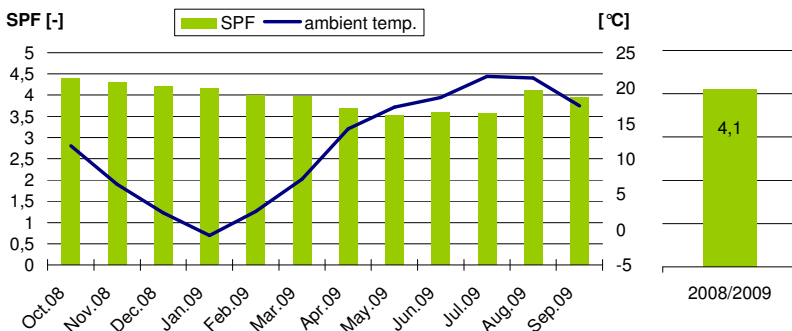

Seasonal performance factor (monthly profile and total value for monitoring period) and ambient temperature (monthly average)

### Performance indicators

#### Seasonal performance factors

<b>Overall SPF SH, DHW and SC:</b>	<b>4.1</b>
<b>SPF space heating:</b>	<b>4.3</b>
<b>SPF domestic water unit:</b>	<b>3.7</b>
<b>SPF space cooling</b>	<b>9.0</b>

#### Operation time:

<b>Heating period:</b>	<b>256 d</b>
<b>DHW period:</b>	<b>year-round</b>
<b>Operation SH</b>	<b>1452 h</b>
<b>Operation DHW</b>	<b>362 h</b>



## System performance and optimisation

The overall generator performance factor of 4.1 is a good value for a ground-coupled heat pump with horizontal collector. Also the single performance factor in the space heating mode is with 4.3 good. The DHW factor is with 3.7 in the upper range of measured seasonal performance factors.

The SPF in passive cooling mode is with 9.0 also in a range which is measured in other field test projects, as well. In systems with borehole heat exchangers, performance factors of 8-15 and seasonal performance factors in the range of 8 have been measured in residential buildings.

The relatively high fraction of auxiliary energy consumption of 45% of the total electricity consumption is also due to the passive cooling operation, since in the summer operation, heat pump electricity is only used for the DHW operation, while in passive cooling operation, only the pumps are operated. The fraction for space heating and DHW is usually in the range of 10%, but the ratio is shifted for systems with passive cooling to higher fractions of auxiliary use. Consequently, this means that the efficiency of auxiliary components has a higher impact on the performance factor, so the choice of pumps and design of the hydraulic system get more important for a good performance factor. In general, the performance of the passive cooling is mainly affected by the hydraulic performance and the cooling needs, since the pump energy is nearly constant and independent of the cooling energy extracted.

## Economy, Ecology and Costs

4

Environmental impact of the heat pump based on thermal energy produced\*:

CO <sub>2eq</sub> emission factor:	370 g/kWh <sub>el</sub> .
CO <sub>2eq</sub> emission***:	977 kg
Primary energy factor****:	1.26 kWh <sub>prim</sub> /kWh <sub>el</sub> .
Primary energy:	3326.4 kWh <sub>prim</sub> .
SPF based on primary energy:	3.25

Condensing gas boiler based on thermal energy produced\*\*:

CO <sub>2eq</sub> emission factor:	247 g/kWh <sub>th</sub> .
CO <sub>2eq</sub> emission***:	2385.7 kg
Primary energy factor:	1.14 kWh <sub>prim</sub> /kWh <sub>th</sub> .
Primary energy:	11010.9 kWh <sub>prim</sub> .
Boiler Efficiency ****:	97 %
Primary energy efficiency:	0.85

\* values based on GEMIS Österreich 4.5

\*\* values based on FANINGER (2007)

\*\*\* values based on produced thermal energy from 10/08 until 09/09

\*\*\*\* value based on SIMADER, 2007

## Conclusion

The presented data confirms that a brine-to-water compact heat pump system can be operated monovalently to cover the entire space heating and DHW energy of a passive house. Due to low flow temperature design of 35°C the SPF of 4.3 in space heating mode is good.

The computed results of CO<sub>2</sub> emissions and primary energy consumption presented above prove that the described heat pump significantly outperforms a condensing gas boiler of high efficiency referring to factors commonly used in Austria.

## Imprint

### System design

Technisches Büro Hauer  
Brückenstrasse 6  
2100 Korneuburg

### Field monitoring

Austrian Institute of Technology (AIT)  
Energy Department  
Sustainable Thermal Energy Systems  
Giefinggasse 2  
1210 Vienna, Austria  
Phone: +43-(0)50550-6309  
Fax +43-(0)50550-6613  
E-mail: [andreas.zottl@ait.ac.at](mailto:andreas.zottl@ait.ac.at)  
Web: <http://www.ait.ac.at>

Date of Best practice sheet: February 2010

## Literature

### Andreas Zottl, Heinrich Huber and Christian Köfinger

Field test of integrated heat pumps systems –  
Field test of 11 heat pump systems,  
IEA HPP Annex 32 report Austria Task 3,  
Austrian Institute of Technology, Vienna, August 2010

## IEA HPP Annex 32

IEA HPP Annex 32 is a corporate research project on technical building systems with heat pumps for the application in low energy houses.

The project is accomplished in the Heat Pump Programme (HPP) of the International Energy Agency (IEA).

Internet: <http://www.annex32.net>

